

STI14100NC STI Universal Stopper

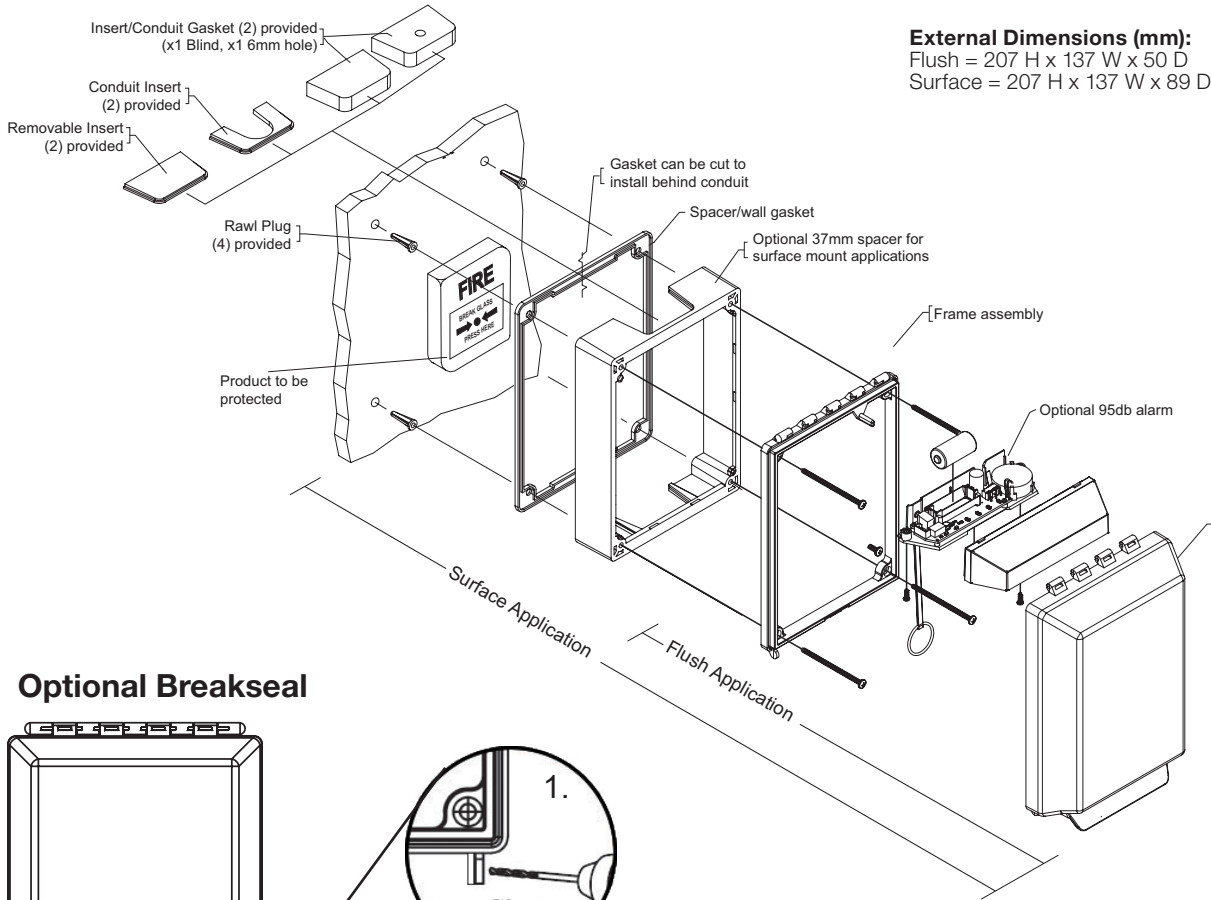

External Dimensions (mm):
 Flush = 207 H x 137 W x 50 D
 Surface = 207 H x 137 W x 89 D

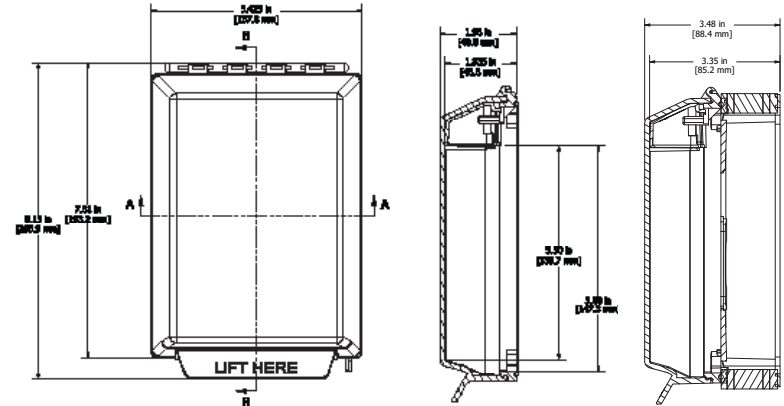

PRODUCT DIMENSIONS

INSTALLATION NOTES

Before drilling mounting holes place spacer, frame and cover over your device. Position it so all aspects of device function properly and cover closes with no interference. If covering a manual call point (MCP) ensure to allow sufficient clearance for re-setting & maintenance.

1. Mark the position for the 4 fixing screws. Drill the holes using a 6mm masonry drill bit and fit the Universal Stopper with wall fixings provided.
2. If using a Surface mounted spacer, please note that it provides cable entry facilities, for conduit, cable and trunking. A 37mm depth spacer is supplied as standard.
3. Where the weather gasket is required, position this between the spacer (surface) and the wall.
4. Ensure the servicing pin is removed from the alarm unit on those fitted with a sounder. The pin should be retained in the event any maintenance is carried out.

Three year warranty or a one year limited warranty (from date of purchase) on most products. See website for details. Electronic warranty form at www.sti-usa.com/wc14.

Optional Breakseal

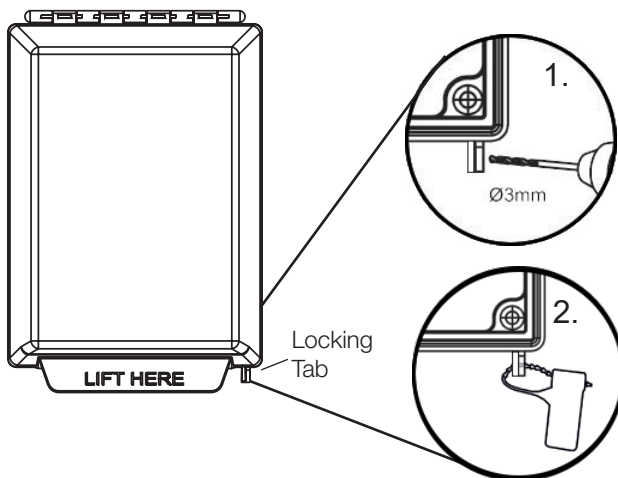

Replacing the battery (STI-14000 Series with Sounder)

To replace the 3V CR123A battery in the alarm unit, lift the cover and insert the servicing pin to silence the alarm, remove both retainer screws on the alarm unit, rotate the unit away from the cover and replace battery. Reassemble ensuring to remove the servicing pin to rearm the unit. The pin should always be retained.

Installation Tools Required:

1. 6mm Masonry Drill Bit
2. Phillips Head Screw Driver
3. 3mm Drill Bit for Break Seal option

Universal Stopper Accessories

STI-1331	37mm Spacer
STI-1314	Universal Stopper Backplate
KIT-EA135	Servicing Pin
STI/BS	Breakseals (Quantity. 10)
KIT-1402	Sounder Cartridge